

EUROSTER UNI3

Weather-based controller for the heating system



MANUFACTURER: P.H.P.U. AS, Chumiętki 4, 63-840 Krobia, Poland

In order to take full advantage of the controller capabilities and ensure proper operation of the system, please read this user manual carefully.

Manual version: 01.08.2016

1. APPLICATION

UNI3 is a universal controller designed to control the heating system equipped with:

- three independent CH heating zones with mixing valves (e.g. for floor heating, radiator heating)
- main heating source – with its own controller, e.g. gas-fired boiler
- additional heating source – e.g. solid fuel boiler, fireplace

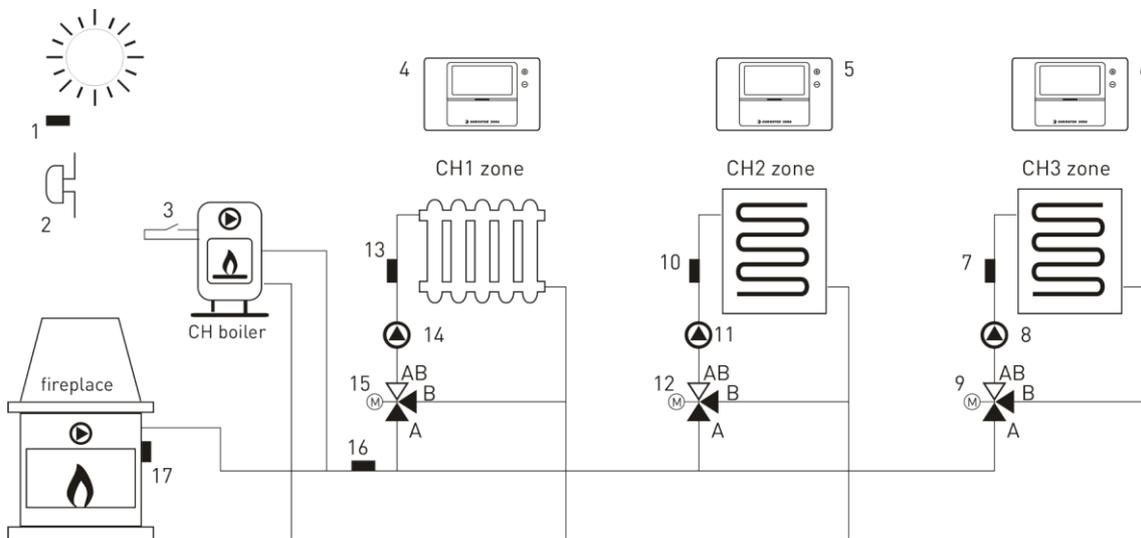

- | | |
|-------------------------------|--|
| 1. Outdoor temperature sensor | 10. Zone 2 temperature sensor |
| 2. Alarm indicator | 11. Zone 2 pump |
| 3. Main boiler switch | 12. Zone 2 mixer |
| 4. Zone 1 room thermostat | 13. Zone 1 temperature sensor |
| 5. Zone 2 room thermostat | 14. Zone 1 pump |
| 6. Zone 3 room thermostat | 15. Zone 1 mixer |
| 7. Zone 3 temperature sensor | 16. Supply temperature sensor for the zones |
| 8. Zone 3 pump | 17. Temperature sensor of an additional heating source |
| 9. Zone 3 mixer | |

ATTENTION! This is a reference drawing which does not contain all components of the system.

ATTENTION! A hydraulic system must enable independent operation of the main and additional heating source.

2. FUNCTIONS

2.1. CH zones

- independent setting of temperature and weather curve for each zone
- independent control of each zone with room thermostat and weekly schedule
- possibility to turn off the mixer control
- possibility to turn the zone off
- manual or automatic switch of summer / winter season – possible setting of starting and ending dates of the heating period
- selection of a zone operating mode: by turning the pump on or off or by decreasing the temperature with a mixing valve with the pump turned on permanently
- cooperation with the floor heating distributors
- possibility to turn on the frost protection mode
- alarm of exceeding the maximum allowable temperature

2.2. Additional heating source zone

- utilizing the heat generated in an additional heating source (e.g. a fireplace)
- automatic switch-off of the main heating source when the additional one is operating
- adjustable shutdown temperature
- alarm indication

2.3. Communication

- possibility to combine several UNI3 and UNI2 controllers
- common weather sensor
- common supply temperature sensor
- common (one) boiler control output
- common (one) control output for audible alarm

2.4. Utility functions

- control of a gas-fired boiler or other heat emitting device with a voltage-free output (no/nc relay contacts)
- utilizing the heat generated in an additional heating source (fireplace, solid fuel boiler)
- alarm output (for connecting a 230 V 50 Hz indicator)
- event log (the controller stores 100 last alarms or irregular situations)
- interface in: Polish, English, German, Czech, Russian, Hungarian
- possibility to test each output independently
- overheating protection for each zone
- overheating protection for supply
- cooperation with systems with high supply temperature (up to 110°C) – upon customer request
- frost protection
- Anti-Stop algorithm – protection of pumps and valves against seizure

3. USER INTERFACE

3.1. Main screen

The following information is shown on the main screen:

- zone temperatures: current and preset (e.g. calculated with a weather-based algorithm)
- active devices (pump, mixer, boiler)
- controller status (anti-stop, disinfection, heating season: WINTER/SUMMER and others)
- time and date

Example of screen with description is shown below.

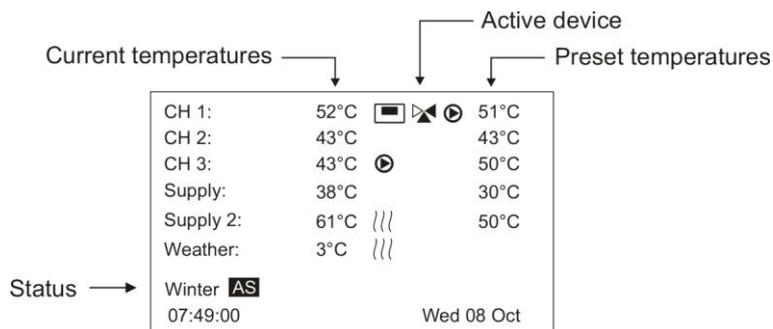

The symbols shown in the controller have the following meaning:



pump operation



mixer operation



heating switched on by a room thermostat



Anti-Stop algorithm active



an error occurs



lack of internal communication



communication with other controller



other controller in the network reports an error



lack (error) of communication between the controllers



boiler output switched on



additional heating source in operation

AF

frost protection switched on

3.2. Multifunction knob

The controller is operated with a multifunction knob. In addition to a rotary face used to change the set value, it contains 4 buttons used for navigation (selecting between menu items: up, down, next, previous) and a confirmation button located in the middle of the knob, which also clears the display of alarm warnings.

ATTENTION! When a setting is changed, the new value is stored after confirming it with the middle or right button.

3.3. LED

A light-emitting diode is located on the left-hand side of the display. The colors mean the following:

- green: Operation without errors
- red: An error has occurred
- blue: Menu active
- yellow: Output testing mode
- in case the communication is active, a diode is flashing when the information is transmitted between the controllers

3.4. List screens

The controller settings are arranged hierarchically, based on the zone --> parameters order. Only the basic settings are available for the user. Advanced options are included in "Settings" and are protected with an access code.

3.5. Setting screens

Selected adjustable parameters with comments are listed below.

3.5.1. User settings

CH1 zone

- **schedule**
It can be used to switch off the zone for selected time on selected days of the week.
- **zone temperature**
It is the zone temperature maintained with the use of the mixer. Three settings: for -20, 0, +10 for work with the weather compensator. One setting for work without the weather compensator.

CH2 zone

- parameters identical to the CH1 zone

CH3 zone

- parameters identical to the CH1 zone

Heating season

Turning the heating season off results in switching off CH zones. The DHW circuits work normally.

WINTER sign is displayed to indicate activation of the heating season and SUMMER is displayed to indicate its deactivation.

- **Auto**
This function enables turning the heating season on and off automatically, according to the preset dates of start and end.
- **switching on/off**
This parameter enables to turn the heating season on or off manually.

Date and time

This window enables to enter current date and time. Please remember that only correct settings enable proper operation of the schedules and controlling algorithms as well as event log and turning the heating season on/off.

Settings

Entering advanced settings (installer settings).

3.5.2. Reset and restoring factory settings

To restart a controller press Reset button, use e.g. a toothpick or a pen. Basic reset does not delete the user settings.

To restore factory settings, press Reset button and hold it for at least 5 s, until "Restoring factory settings" is displayed.

After restoring factory settings language selection menu is displayed and operation parameters of the system zones must be set up again.

3.5.3. Installer settings

The installer settings are available after entering the access code. **The default code is "1, 2, 3".**

ATTENTION! It is recommended to restore factory settings before configuring a new controller.

Setting for CH1, CH2, CH3 heating zones are identical.

- **switching on/off**
This item enables to turn off the unused zone.
- **Mixer**
 - **turning the mixer on/off**
This option enables to turn the mixer control off if it is not used in the CH zone. In such case the (current and preset) temperatures are not displayed for the particular zone.
When operating with the mixer switched off the functions responsible for controlling the temperature and the continuous operation function are not available.
 - **mixer dynamics**

Determines the mixer response time to changes in the zone temperature. An excessive value may cause frequent cycling of the mixer, whereas the insufficient value may cause slowness in achieving the preset temperature.

- **mixer hysteresis**

If the measured temperature of the zone differs from the preset one by half of the value of the preset hysteresis, then the mixer position is not corrected.

- **alarm temperature**

ATTENTION! Alarm temperatures for all zones should be selected carefully. Incorrect setting of temperature level may cause improper operation or major failure of the system components.

The alarm temperature should be preset as the maximum safe temperature for a particular zone.

- **room thermostat**

This item enables to turn on/off the control of room thermostat inputs.

- **continuous operation, reduction of CH temperature**

In certain cases continuous operation of the central heating pump is recommended regardless of whether the room is fully heated or not. In such case the "continuous operation" option should be activated. Heating is then switched off by reducing the temperature of the heating medium with the mixer, without switching the pump off. The zone temperature is reduced by the value determined with the "CH temperature reduction" parameter.

When the "continuous operation" option is turned off, the pump will be turned off once the mixer is closed (when the room thermostat or schedule requests the circulation turn-off).

The pumps are also switched off when the supply temperature drops below the shutdown temperature.

- **weather compensator**

Using weather compensation enables to achieve thermal comfort regardless of external temperature. After activating the weather compensator it is required to connect an outdoor temperature sensor.

After switching the weather compensation on, temperatures of the CH zones for three outside temperatures should be set. Based on them the controller calculates the currently required zone temperatures every 10 minutes.

ATTENTION! Temperatures must meet the condition of: $T_{10^{\circ}\text{C}} \leq T_{0^{\circ}\text{C}} \leq T_{-20^{\circ}\text{C}}$, otherwise the control will not work properly.

- **frost protection, anti-frost temperature**

The anti-frost algorithm is activated when the temperature of the particular zone sensor drops below the preset level. In such case both the boiler and the pump are activated. The schedule settings do not affect the operation of this protection.

ATTENTION! The protection is disabled by default.

- **sensor correction**

CH1, CH2 or CH3 zone sensor correction allows to correct temperature reading errors, such as the ones resulting from improper contact between the sensor and the pipe.

- **test**

The test option allows to switch on the connected devices manually. For safety reasons, when the selected output is being tested, all other outputs are switched off.

Supply

- **shutdown temperature**

The controller operates only when the supply or supply 2 temperature is higher than the preset shutdown temperature. It is aimed at reducing consumption of electricity.

- **shutdown hysteresis**

It is a parameter which is added to the preset shutdown temperature in order to determine the temperature based on which the controller switches the heating zones on, e.g.

shutdown temperature – 30°C, shutdown hysteresis – 5°C, the controller turns on the heating zones when the supply temperature reaches 35°C.

- **excess of supply**
The excess of supply parameter determines by how much the supply temperature should exceed the temperature calculated by the controller for zones. It allows the user to set the proper temperature at the boiler (temperature item required for supply).
- **supply alarm temperature**
If the alarm temperature is exceeded at the supply, the alarm algorithm is activated to attempt to cool down the boiler.
ATTENTION! The alarm algorithm heats zones to temperatures approximate to alarm temperatures. It is important to ensure safe level of alarm temperature for each zone.
- **Frost protection**
If the temperature of the supply sensor drops below the preset temperature, the controller switches on the transmitter which controls the boiler, and "AF" sign flashes on the display.
- **supply sensor correction**
Supply temperature sensor correction allows to correct temperature reading errors, such as the ones resulting from improper contact between the sensor and the pipe.

Supply 2

- **switching on/off**
Switches operation of the additional heating source on or off.
- **shutdown temperature**
Above the shutdown temperature for the additional heating source, the controller will turn off the relay of the main heating source. Then the system will be fed from the additional heating source only.
- **shutdown hysteresis**
It is a parameter which is added to the preset shutdown temperature in order to determine the temperature based on which the controller switches on the heating zones and switches off the basic heating source.
Shutdown temperature for supply 2 – 40°C, shutdown hysteresis – 5°C, the controller will switch on the heating zones (in case the basic supply temperature is below the shutdown temperature) and switch off the main heating source, when the supply temperature reaches 45°C.
- **supply alarm temperature**
If the alarm temperature is exceeded at the supply, the alarm algorithm is activated to attempt to cool down the boiler.
ATTENTION! The alarm algorithm heats zones to temperatures approximate to alarm temperatures. It is important to ensure safe level of alarm temperature for each zone.
- **Frost protection**
If the temperature of the supply sensor drops below the preset temperature, the controller switches on the transmitter which controls the boiler, and "AF" sign flashes on the display.
- **supply sensor correction**
Supply temperature sensor correction allows to correct temperature reading errors, such as the ones resulting from improper contact between the sensor and the pipe.

Common

- **external sensor correction**
Correction allows to correct temperature reading errors, such as the ones resulting from improper location of the sensor. Item active when weather compensation is active.
- **audible alarm**
The "audible alarm" allows to switch off audible alarms generated by the controller. This does not affect the operation of the alarm output.
- **Communication**
 - **switching on/off**
Enables to switch on communication control. Do not switch on communication when the controllers are not connected into a network.
 - **device addresses**

Enables to determine the addresses of individual inputs and outputs.

Device addresses	Description
Proper	Physical address of the particular controller (identifier). Range from 1 to 247. For the proper functioning each controller in the network must have a unique address assigned.
Supply sensor	Identifies a controller that feeds a supply temperature. It may be a proper address or an address of another controller.
External sensor	Identifies a controller that feeds an external temperature. It may be a proper address or an address of another controller.
Boiler output	Identifies a controller with a boiler output active. It may be a proper address or an address of another controller.
Alarm output	Identifies a controller with an alarm output active. It may be a proper address or an address of another controller.

- **DHW priority – CH1, CH2, CH3**

In case of connecting UNI 2 and UNI 3 controllers and using DHW priority function, it is possible to define, which zones are to operate the DHW tank feeding priority. The priority switched on – a particular zone will be switched off during feeding of the DHW tank; the priority switched off – a particular zone operates according to its settings while feeding DHW tank.

ATTENTION! If only one UNI controller is operating in the system, or connection of independent supply and external sensors for each controller is not problematic, then the communication should not be switched on. Installing the controller functions as parallel to each other will improve reliability of the whole system.

Each controller in the network must have a **unique** address – identifier assigned. During the manufacturing process randomly selected addresses are assigned to each controller, however each system is different and generally requires to assign its own addresses.

Assigning an address in the field of the chosen temperature sensor indicates which controller will feed the measured temperature. It may be a proper address or an address of another controller.

More information is included in "Installation" Chapter.

- **alarm test**
Enables to switch on the external alarm output manually.
- **boiler test**
Enables to switch on the voltage free output of the boiler.
- **Language**
- **events**
The device records the hazardous events. The display shows subsequently: Event number (from the time of installation), date, time and comment, e.g. 30. 19-09 14:16:38 CH1 overheating.
- **version**
When contacting the technical service, please provide the software version numbers. These are two dates.
A: 23:07 24/4/2014 – display driver program
B: 10:08 10/2/2014 – relay driver program

4. INSTALLATION

4.1. Connection

GENERAL SAFETY RULES

- **It is necessary to read this user manual carefully prior to the commencement of the installation works. Incorrect installation and improper use may lead to a serious hazard to a user or other persons and result in material damage! Prior to mounting or dismantling and maintenance of the controller, make sure that it is de-energized!**
- **Dangerous voltages, hazardous to life, may be present on the controller and its cables, therefore only qualified technicians holding authorization for electrical works may be entrusted with the installation of the controller!**

- **Do not install the controller in rooms of increased humidity, substantial dustiness or with presence of caustic or flammable vapors, protect it against water and other liquids!**
- **Do not install any controller showing signs of mechanical damage.**
- **The controller is not a safety component of the heating system in the systems with a risk of damage.**
- **In the case of failure of control systems, use additional protective equipment.**
- **Pay careful attention to correct connection of protective conductors (PC) when connecting power cables!**
- **Do not misuse the controller!**
- **The device is not intended for use by children!**
- **Failure to meet the safety and maintenance rules results in loss of warranty!**



**Temperature sensors are not adapted to immersion in liquids.
The controller works only with actuators equipped with limit switches.**

The controller should be installed in a place where the temperature does not exceed 40°C. Lead all necessary cables prior to mounting the thermostat. The controller is designed for mounting on 35 mm DIN rail. It is recommended to install the controller in a protective cabinet.

Screw the electric cables to the connection blocks according to the description and drawing. Make sure to keep the proper designation of the cables. Screw the neutral conductors to N terminals, phase conductors to L terminals and grounding conductors to PE terminals. Use cable with minimum diameter of 0.75 mm² for connection.

The controller is equipped with six temperature sensors. Connecting the sensors related to zones / functions that are switched off is not necessary.

The controller sensors may be connected in any way, with no need to keep cable polarity. At installation avoid leading the sensors parallel to live cables. Moreover, make sure to provide the proper contact with measured surfaces.

Outdoor temperature sensor should be installed in a shaded place, away from windows and doors, at a height of approximately 2 m above ground.

Similarly, a room thermostat control may be switched on or off for each heating zone. It is only allowed to use controllers with **voltage-free normally open (NO) contact**. It is recommended to use Euroster devices.

ATTENTION! Euroster UNI3 controller and a heat emitting device are connected to the "Boiler" output and must be powered from the same phase of the power system.

Connection diagram is shown below.

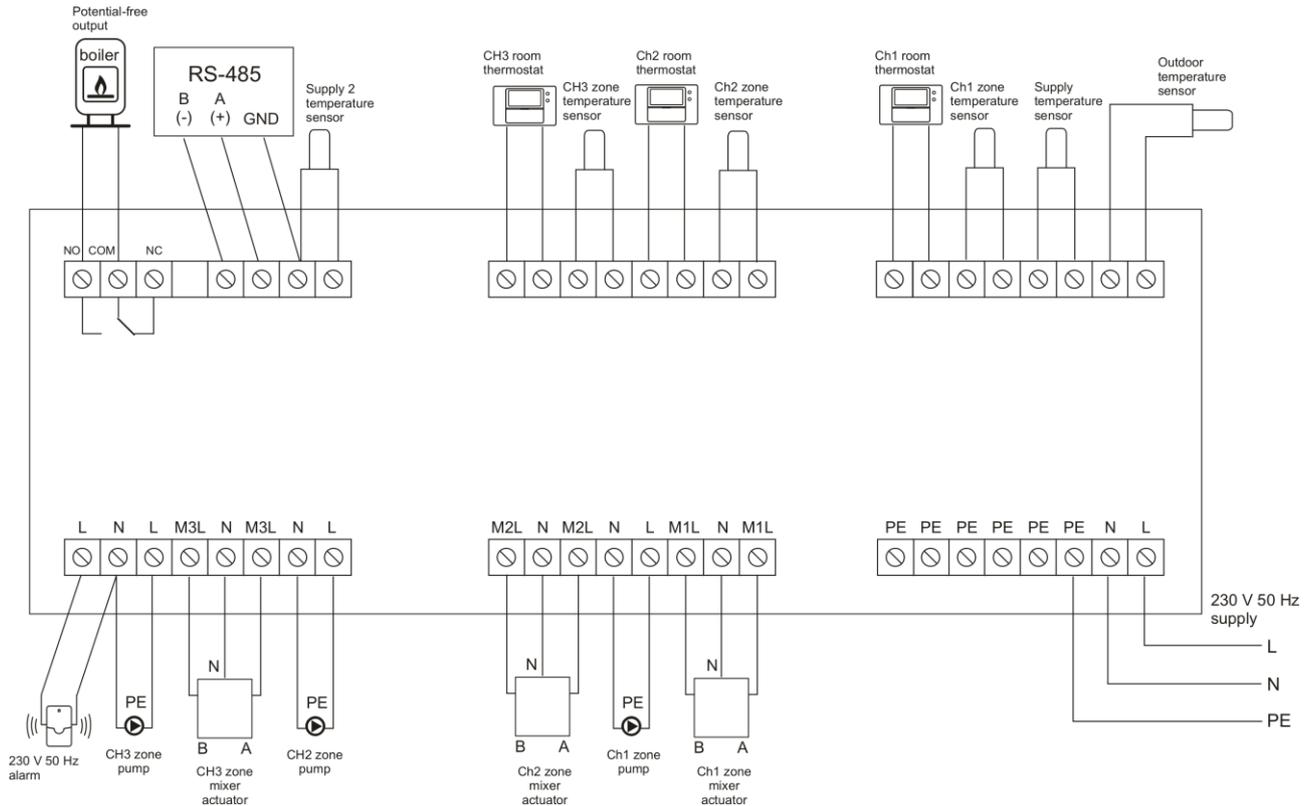

4.2. Maintenance

Before each and every heating season, the controller must be cleaned of any dust and dirt, the cables must be checked for tight fixing. If necessary, wipe it carefully with a soft cloth. Do not use solvents and aggressive detergents since they may damage the surface of the housing and the display. Avoid contact with water or other liquids.

4.3. Communication

4.3.1. RS-485 connection

UNI3 controller enables communication with use of RS-485 interface. The connection should be made with use of a shielded twisted pair in bus topology. A, B and GND terminals of the controller should be connected with A and B cables of the bus and a shield (figure).

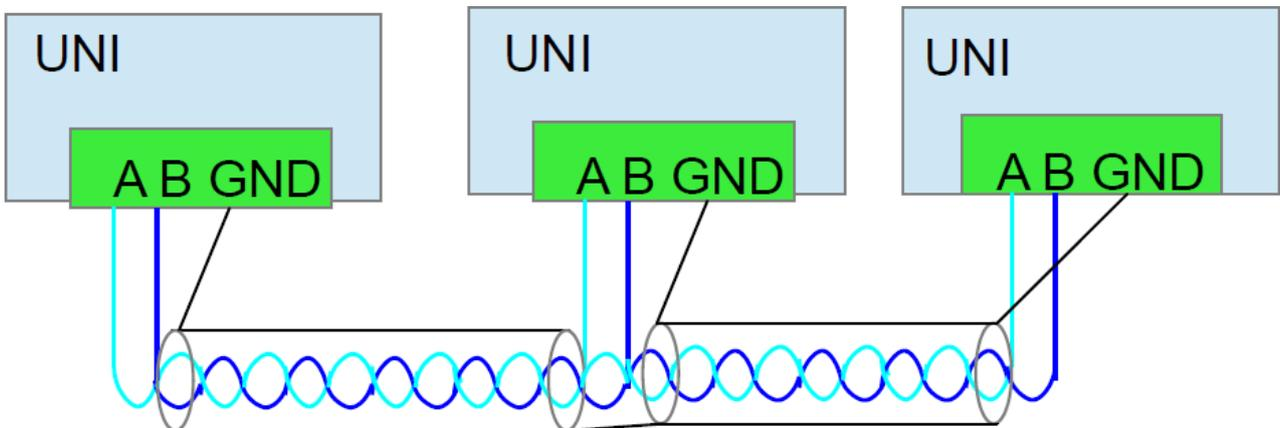

The controllers are equipped with a linear polarization and return loss system. It is sufficiently effective in case of short connections. With connections of several hundred meters, termination resistors with resistance of 120 Ω should be placed at both ends.

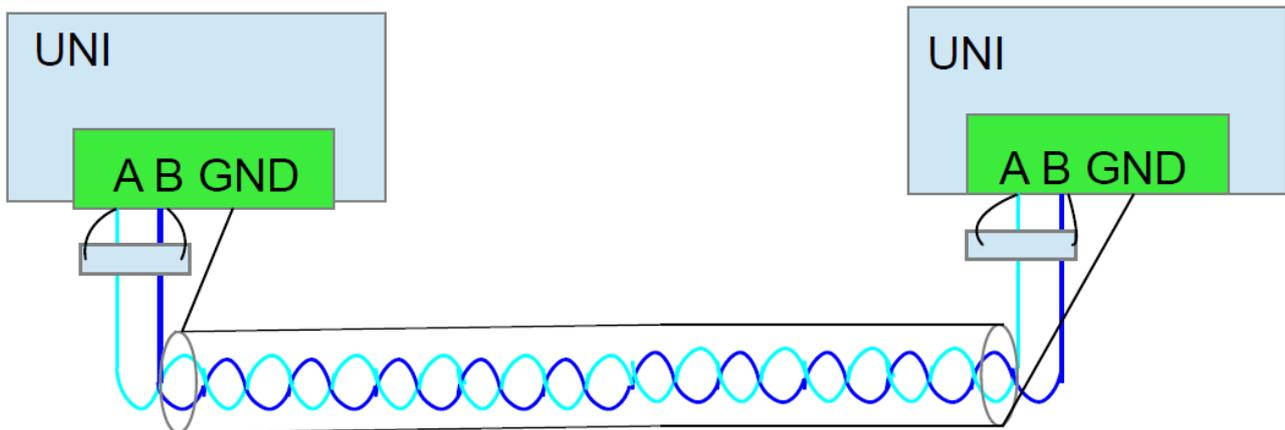

4.3.2. Address allocation

After connecting a twisted pair, activate the communication and select the addresses of controllers in all connected controllers. Each of the controllers must be provided with a different address. It is advised to write down the addresses in a visible place in a boiler room, which will facilitate the configuration process.

4.3.3. Boiler control

The communication feature enables to control the boiler with the use of one controller output. The boiler will be switched on by any controller in the network.

UNI3 operates additional heating sources. This function is strictly connected with controlling the main boiler and is not operated by the communication protocol (it does not feature in UNI2). Therefore, in case of using an additional heating source, the operation of the additional heating source must also be switched on in the controller that switches on the main boiler. In other words, the main boiler must be connected to the output of the same controller, to which the sensor of the additional heating source is connected.

Moreover, in other controllers the parameter of boiler output to the address of the controller which controls the boiler should be set.

Sample configuration of UNI 2 and UNI 3 controllers connected to each other:

Address	UNI2	UNI3	Description
Proper	1	2	Unique address of each of the devices.
Supply sensor	1	1	A common supply sensor connected to UNI2 controller is used.
External sensor	2	2	A common supply sensor connected to UNI3 controller is used.
Boiler output	1	1	A common boiler switch-on output in UNI2 controller is used.
Alarm output	1	2	Alarm outputs are individual in each controller separately (assigned proper addresses).

5. CONTROLLER OPERATION

ATTENTION! Once the controller is switched on the Anti-Stop algorithm is activated (pump and mixer outputs are switched on for 30 s). The Anti-Stop mode is repeated every two weeks, regardless of the heating season.

5.1. Supply temperature

UNI3 controller does not affect the temperature at the boiler (system supply). However, it calculates it and shows it on the display, and the user should ensure that the supply temperature exceeds the temperature currently required by the controller (although does not exceed the alarm temperature). Otherwise, it is not possible to maintain proper temperatures in the system.

Supply temperature is available for the controllers in the network. The controller may read this temperature from another controller if it has its address set up.

5.2. Additional heating source temperature

Activation of the additional heating source interlocks switching on of the main boiler supply. The system must be designed in order to allow independent operation of both heating sources.

5.3. Outdoor temperature

Outdoor temperature is used by the weather compensator.

Outdoor temperature is available in the network. The controller may read this temperature from another controller if it has its address set up.

5.4. Heating zones

Heating in the selected zone is active if:

- a given CH zone is active
- heating season (WINTER) is switched on
- the current time is selected in the schedule of the zone
- room thermostat is active or operation with room thermostat is switched off
- supply temperature exceeds the required one

In case of a complete closure of the mixer, the circulation pump will be switched off. However, if a "continuous operation" option was switched on, the pump works non-stop and the room temperature is controlled with zone temperature control. Detailed description is included in part "3.5.3. Installer settings".

Activating the mixer control slightly modifies the pump operation – it is switched on/off according to the heat demand regardless of the mixer status.

ATTENTION!

The temperature preset for each CH zone **is not displayed** if:

- CH zone is switched off
- room thermostat achieved a target temperature and switched the zone off
- there is a stoppage set up in an operation schedule of the selected zone
- mixer control is switched off
- DHW priority function is active

5.5. Alarm output

Alarm output is used to connect an additional, external alarm indicator. In case of sensor damage, zone overheating or other errors, voltage is supplied to the alarm output.

ATTENTION! Alarm indicator must be adjusted to the network voltage of 230 V.

Simultaneously, appropriate information with the time of error will be displayed.

Alarm output may also be activated with any of the controllers in the network, provided that the address of the controller to have an alarm activated is recorded.

5.6. Boiler output

Boiler output is used to switch the heating source on, e.g. gas-fired boiler. It has 3 contacts marked as NC, NO and COM. They are galvanically isolated from the rest of the system. They withstand mains voltage of 230 V and load of 4 A.

The boiler output is switched on if there is a need to heat any of the zones in any of the controllers in the network and an additional heating source is cold.

5.7. The operation of the controller in arrangement without supply temperature sensor

In case if supply temperature sensor is not used, RZ resistors (included in the kit) with 1K5 value should be installed instead.

The temperature at the supply part of the heating system will be approximately 83°C, which will enable the correct operation of all algorithms.

6. POSSIBLE ERRORS IN THE CONTROLLER OPERATION

6.1. A selected zone is not heating – closed valve or inactive pump

Check:

- whether the heating season is switched on
- whether correct date (day of the week) and time is set
- whether heating is active in the schedule for the current day of the week and time
- in the system with weather compensator – whether the outdoor temperature reading is correct and whether the temperatures are set correctly
- in the system without weather compensator – whether it is switched off in the controller
- in the system with the room thermostat – whether it is switched on and whether it is correctly connected to the controller
- whether the mixer is not connected inversely and whether it is not jammed
- whether the supply temperature is higher than the shutdown temperature
- in case of communication, check whether the addresses are assigned correctly

6.2. A selected zone is subject to overheating

Check:

- whether the valve is not blocked
- whether the mixer actuator is operating
- whether the actuator cables are connected properly
- the value of the mixer dynamics

6.3. “Automatic reset” message

Identify the conditions under which reset occurs. Write down the software version. Consult the technical service.

6.4. Lack of communication

Check:

- if the communication is switched on
- if there is a unique address assigned to each controller
- if the entered addresses of the sensors and outputs correspond to the addresses of the controllers
- if the voltages on A and B (RS-485) terminals in all controllers with no twisted pair connected are similar to the voltages of the twisted pair

7. DIMENSIONS

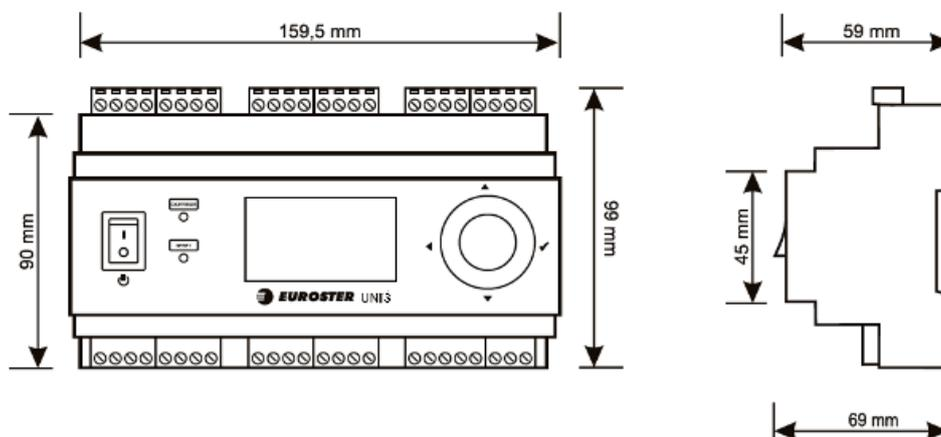

8. TECHNICAL DATA

Supply: 230 V 50 Hz

Maximum power consumption: 4 W

Maximum output load: 100 W (each output)

Temperature control range: 15°C...90°C

Temperature measurement range: -30°C...120°C

Temperature control and reading accuracy: 1°C

Operation temperature range: 0...40°C

Storage temperature range: 0...55°C

Ingress protection rating: IP20

Color: gray, RAL7035

Mounting method: 35 mm DIN rail-mounted, inside electrical cabinets

Alarm output: 230 V 50 Hz

Boiler output: voltage-free type, no/nc, maximum load: 4 A 230 V 50 Hz

Pump power outputs: 230 V 50 Hz

Power outputs of mixer actuators: 230 V 50 Hz

Controller weight: 545 g

9. KIT CONTENTS

UNI3 CONTROLLER

Outdoor temperature sensor (5 m)

Supply temperature sensor (1.5 m)

Temperature sensor of an additional heating source supply (1.5 m)

CH zone temperature sensor (1.5 m) – 3 pcs

Sensor hose clips (5 pcs)

Screw anchors for the outdoor temperature sensor – 2 pcs

User Manual with Warranty Certificate

Power cable (1.5 m)

10. SIMPLIFIED DECLARATION OF EU CONFORMITY

P.H.P.U. AS AGNIESZKA SZYMAŃSKA-KACZYŃSKA hereby declares that the type of EUROSTER UNI3 equipment conforms to the following directives: 2014/35/EU (LVD), 2014/30/EU (EMC), 2011/65/EU (RoHS).

The complete text of the Declaration of EU conformity is available at the following Internet address: www.euroster.pl

ELECTRONIC WASTE MANAGEMENT INFORMATION



This product is designed and manufactured of high quality materials and components suitable for reuse.

The crossed out wheeled bin symbol located at the product means that the product is subject to selective collection in accordance with the provisions of the Directive 2012/19/EU of the European Parliament and of the Council.

The product contains an internal battery subject to the selective collection in accordance with the provisions of the Directive 2006/66/EC of the European Parliament and of the Council.

Such marking informs that the electrical and electronic equipment and batteries may not be disposed of together with other household waste after their service life. The user is obliged to take the used devices and batteries to a point of collection of waste electrical and electronic equipment and batteries. The entities collecting such equipment, including the collection points, shops, and municipal entities, set up an appropriate system enabling handover of such equipment and batteries.

The proper disposal of waste equipment and batteries contributes to prevention of consequences hazardous to the health of persons and nature, resulting from the possible presence of hazardous components in the equipments and batteries and from inaccurate storage and processing of such equipment and batteries. The guidelines regarding disposal of the batteries are included in the user manual.

A household plays an important role in contributing to reuse and recovery including recycling, of the waste equipment. The attitudes influencing protection of the common good of clean environment are shaped at this level. Households are also one of the larger users of small equipment and its rational management at this stage impacts the recovery of recyclables. Inaccurate disposal of this product may be penalised in accordance with national legislation.

