

## EUROSTER 4020TXRX

Wireless, daily room thermostat for all types of heating and air-conditioning devices.

**MANUFACTURER: P.H.P.U. AS, Chumiętki 4, 63-840 Krobia, Poland**

In order to take full advantage of thermostat capabilities please read this installation and operation manual carefully.

This manual is intended for the 11.09.2020 version of the thermostat.

### 1. THERMOSTAT APPLICATION

**Euroster 4020TXRX** is a user-friendly thermostat designed for controlling the temperature in living and utility rooms within a temperature range of 5 °C...35 °C. It is used to control the operation of the CH boiler and other heating system components. It controls electrical equipment, floor heating, and air-conditioning systems. The sensor used in **Euroster 4020TXRX** enables temperature read-out and programming accuracy of 0.1 °C. It features a function to lower the preset temperature for the night. The preset temperature is modifiable within the range of 5 °C...35 °C. The thermostat is programmable in daily operating cycles.

### 2. BASIC THERMOSTAT FUNCTIONS

- Does not require leading cable connections between the thermostat and the controlled device
- User-friendly thermostat enabling easy control of temperature in living and utility rooms
- Bidirectional communication ensures high operational reliability and resistance to interference
- Possible cooperation with up to 6 Euroster RX receivers
- Function enabling a temporary decrease of the set temperature
- Legible, backlit LCD
- Thermostat interlock with a selectable 3-digit code
- Operation in one of the following three operation modes:
  - ✓ Room temperature control mode
  - ✓ Floor temperature control mode
  - ✓ Temperature control with floor temperature limitation mode
- Simultaneous display of current and preset temperature value
- Enables hysteresis setting between 0.2°C and 10°C or PWM adjustment
- Temperature setting and read-out accuracy of 0.1 °C
- Possibility to switch the thermostat off after the heating season
- Discharged batteries indication
- Temperature read-out correction
- Surface mounting

### 3. THERMOSTAT VISIBLE ELEMENTS

#### BODY

- a. Thermostat on/off switch
- b. Thermostat control knob
- c. Display

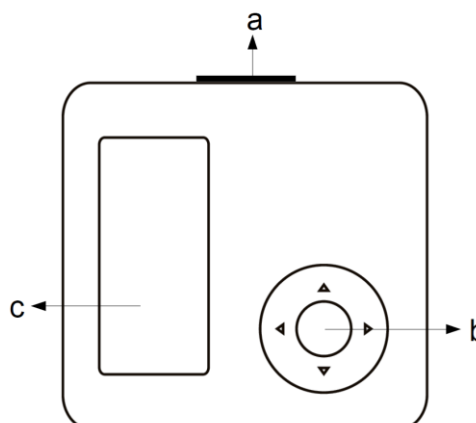

### DISPLAY

- A. Radio communication symbol
- B. Current temperature
- C. Active function enabling a temporary decrease of the preset temperature
- D. Preset temperature
- E. Active heating symbol
- F. Active thermostat interlock symbol

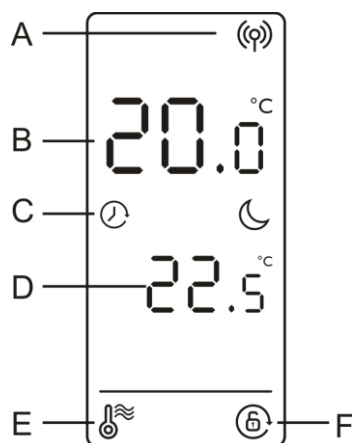

### 4. VISIBLE ELEMENTS OF RX RECEIVER

- A. On/off switch for continuous operation of the heating device
- B. Button with signaling LEDs used to enter settings
- C. Output cable

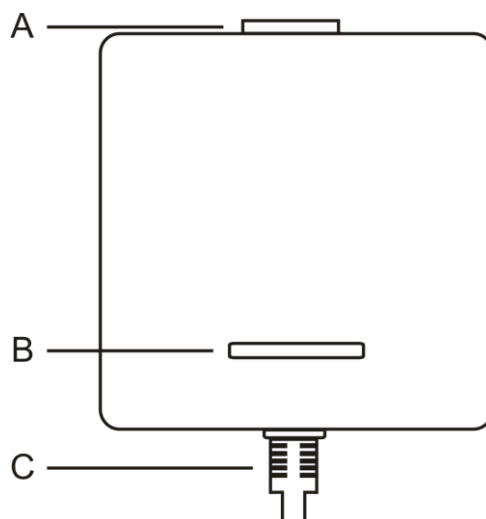

### 5. INSTALLATION

#### 5.1. Safety rules

##### CAUTION!

- Prior to the commencement of any installation works read this manual carefully! Incorrect installation and improper use may lead to serious hazards to users or other persons and result in property damage!
- Prior to mounting or dismantling the set make sure that the heating/cooling system is de-energized!
- Voltages hazardous to life may be present on receiver output cables (power supply phase voltage), therefore only qualified technicians may install the thermostat!
- The electric connections performed and cables used shall be adequate to the applied loads and must conform to all requirements!
- Do not install the set in rooms with increased humidity; protect it against water and other liquids!
- Do not install any unit showing signs of mechanical damage!
- The thermostat is not a safety component. Additional protection devices must be used in systems prone to the risk of damage due to the failure of control systems!
- The device is not intended for use by children!
- Should there be any problem with the proper operation of the thermostat, please contact your technician or the manufacturer!

## 5.2. The proper place of installation

The thermostat is designed for indoor installation. In order to ensure fully efficient operation of the thermostat, please make sure that the following recommendations regarding the location of the thermostat are observed:

- Locate the thermostat at the height of approximately 1.5 m above the floor
- Avoid places with strong sunlight, near heating or cooling devices, situated directly by doors, windows, and other similar locations, where the temperature measurement could be easily disturbed by external conditions.
- Avoid places with poor air circulation, e.g. behind furniture.
- Avoid moist places due to the negative effect of moisture on the service life of the device.

## 5.3. Insertion and replacement of batteries

Place the batteries in the thermostat while observing the correct polarity. There are installation markings in the battery compartment. Then install (snap) the thermostat onto the base.

**CAUTION! Use only alkaline AAA batteries to power the thermostat. Do not use rechargeable batteries because their voltage is lower, and their effective time is shorter.**

**It is recommended to replace batteries before each heating season.**

## 5.4. Sample Connection Diagrams

The following diagrams are simplified and do not cover all elements necessary for the correct installation.

### In arrangement with a 230 V 50 Hz device

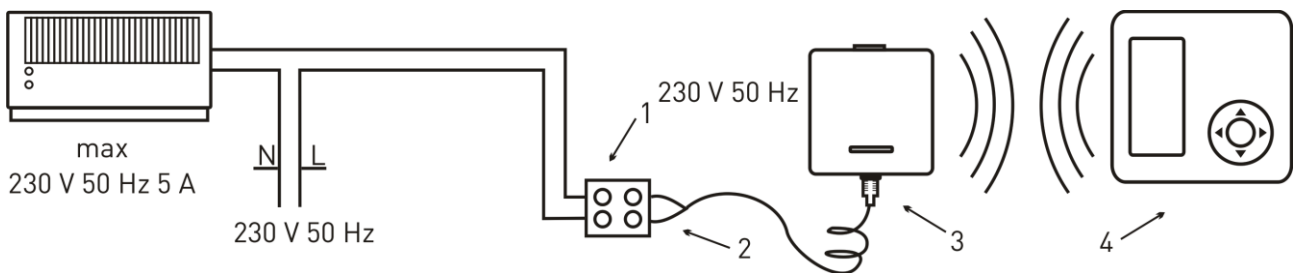

1. Electrical connection block
2. Output cable using COM - NO contact (normally open)
3. Euroster RX (receiver)
4. Euroster TX placed in any room

### In a system with a gas boiler

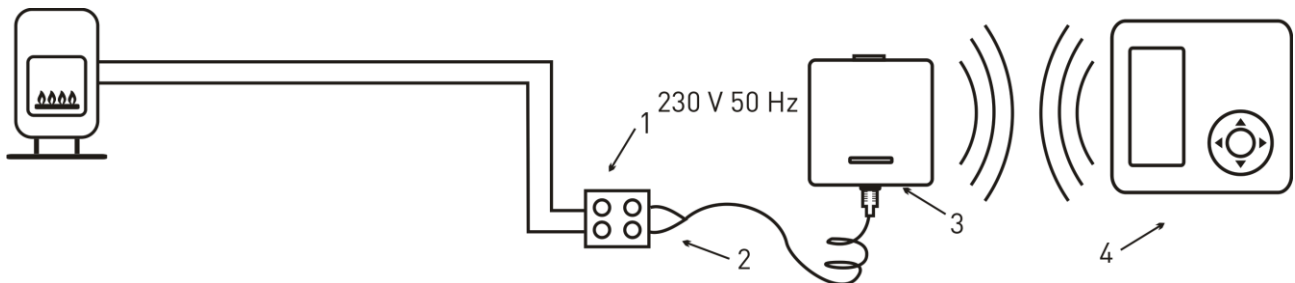

1. Electrical connection block
2. Output cable using COM - NO contact (normally open)
3. Euroster RX (receiver)
4. Euroster TX placed in any room

## 5.5. SETTING TEMPERATURE

Use the "▼" and "▲" buttons to set the desired temperature value. Pressing one of the buttons for the first time activates the backlight, pressing it repeatedly lowers or raises the

temperature in increments of 0.1°C. The longer the button is pressed, the faster the values change. Confirm the temperature change with the central button or wait until the set value stops flashing and is stored. The factory setting is 20 °C.

## 6. FUNCTION ENABLING TEMPORARY DECREASE OF THE PRESET TEMPERATURE



It allows you to store the lowered temperature (☾) and its duration and the comfort temperature (☀) that will remain in effect for the remaining time of the day. The preset program will be executed every day of the week.

To activate the function:

- Use the "▼▲" buttons to set the comfort temperature
- Confirm with the central button
- Press and hold the central button for 3 seconds
- The display shows the flashing value to be used as lowered temperature (☾ symbol),
- Use "▼▲" buttons to set the desired temperature value
- Confirm with the central button
- then use the "▼▲" buttons to set the duration of the operation with lowered temperature.
- Confirm with the central button

From this point on, the thermostat runs the program for all days of the week. For the duration of the operation with decreased temperature, the ☾ symbol is displayed, and the ☀ symbol is displayed for the remaining time of day.

In order to change the set temperatures without disabling the function:

- Press the right-hand "▶" button
- Press the right-hand button again – select comfort ☀ or reduced ☾ temperature
- Use "▼▲" buttons to set the desired temperature value
- confirm with the central button.

In order to disable the function, hold down the central button for 3 seconds.

The function of temporarily lowered temperature can be set to between 1 and 23 hours.

## 7. TEMPORARY CHANGE OF TEMPERATURE

During the thermostat operation with the temporarily lowered temperature, use "▼" and "▲" buttons to change temperature. However, the changed temperature value is only valid until the next change resulting from the preset lowering period. For the time of temporary operation with changed temperature "☞" symbol is displayed.

## 8. THERMOSTAT CONFIGURATION

Press and hold the central and right buttons for approximately 2 seconds to enter the setting mode. Configure the thermostat in the following way: choose a required parameter with "▼" and "▲" buttons, use the central button to enable the introduction of changes, and change the value using "▼" and "▲", then confirm the modified value with the central button. The following parameters may be changed:

- **Temperature range limit – low (LO)**

This parameter allows you to limit the temperature range to be set. This parameter limits the lower values of the range.  
Default value 5°C.

- **Temperature range limit – high (HI)**

This parameter allows you to limit the temperature range to be set. This parameter limits the higher values of the range.  
Default value 35°C.

*Example:*

*To set a preset temperature between 18 °C and 23 °C, you must set the "LO" value to*

18 °C and the "HI" value to 23 °C.

- **Hysteresis/PWM (H)**

Two operational options for activating the heating algorithm are available: hysteresis or PWM.

In the case of hysteresis, the device is activated based only on a difference between the preset and current temperature. The parameter determines the accuracy of room temperature control. You may set the hysteresis between 0.2 °C and 10 °C, and the factory setting is 0.4 °C.

Setting the value to 0.0 will put the thermostat into PWM mode.

PWM is a more advanced method to achieve the preset temperature. It is suited for systems with underfloor water heating. It is used to limit room temperature fluctuations. Unlike in on/off controls, the current status of the transmitter depends not only on the current difference between the preset and measured temperature but also on the past changes of temperature. PWM operates with fixed parameters:

- ✓ Minimum relay activation time of 3 minutes,
- ✓ Number of cycles per hour - 4
- ✓ Operating range of the PWM algorithm of 0.7 °C.



- **Thermostat interlock (Pin)**

The thermostat features a keypad lock function. A three-digit code of your choice may be entered. In such a case it is not possible to change the settings. The interlock does not affect the thermostat operation. To activate the interlock, change "OFF" to "On", in the menu, confirm with the central button, then enter the code using the "▲▼" buttons. Confirm each digit with the central button. Active interlock is indicated by displaying the  icon. The interlock is active after 10 minutes. The interlock is disabled in the same way. This function is not active by default.

- **Temperature sensor correction (C)**

It is a value added to or subtracted from the measured temperature value. It adjusts the displayed temperature within the range of +/- 5 °C. The function is convenient if the thermostat is located in a slightly warmer or cooler area of the room.

- **Heating / Cooling (t)**

Select whether the thermostat operates in heating –  symbol or cooling  symbol mode.

In the cooling mode, the device connected to the thermostat will be switched on when the temperature increases above the preset level.

- **Selection of temperature sensor (Sen)**

This option permits the selection of a temperature sensor to cooperate with the thermostat. There are three operation modes available:

- ✓ **0** – the thermostat measures and maintains the temperature based only on internal sensor operation
- ✓ **1** – the thermostat measures and maintains the temperature based only on external (cabled) sensor operation
- ✓ **2** – the thermostat measures the temperature of both sensors; it maintains the temperature of an internal sensor, and the external sensor acts as a temperature limit. Having selected this operation mode set the floor temperature limit value. This parameter is used to establish the maximum safe floor temperature. When the preset temperature is reached, the heating gets switched off.

- **Pairing mode (P)**

Used to establish radio communication between the thermostat and receiver(s). For pairing mode, see section 12.1.

- **Reset (rEs)**

When you change the value from 0 to 1, the thermostat restores factory settings.

- **Exit (ESC)**

Press the central button to make the thermostat exit the service mode.  
You may also exit the menu by pressing the left "◀" button.

## 9. TEST MODE (tSt)

In the test mode, you may check the main parameters of the thermostat. To enter the test mode press and hold the central and "◀" button for approximately 2 seconds.

The following tests are available:

- internal sensor temperature measurement
- external sensor temperature measurement - press the central button,
- relay test - press the lower "▼" button repeatedly to switch the relay on/off,
- backlight test - press the upper "▲" button repeatedly to switch the backlight on/off.

## 10. SWITCHING THE THERMOSTAT OFF

When the switch is moved, the thermostat goes into frost protection mode. The  icon appears on the display. Frost protection ensures that the heating is turned on only to prevent the temperature from dropping below 4°C.

## 11. ERROR INDICATION

**OP** – sensor missing or damaged

**SH** – short-circuit of a sensor or a damaged sensor

**Err 1** – internal error– remove and after a few moments reinstall the batteries.

 – discharged batteries icon.

**Err** and  symbol – no radio communication.

## 12. RX RECEIVER SETTINGS

### 12.1. Establishing a connection between 4020TX thermostat and RX receiver or receivers (pairing)

Each thermostat and each receiver has a unique number that distinguishes it from others. It is not possible for any thermostat not paired with the particular receiver to interfere with the operation of another pair or set.

The thermostat may be paired with other receivers at any time. A blackout, battery replacement as well as a complete reset of all thermostat settings do not affect the pairing of devices in any way.

Pairing procedure:

- Enter the configuration mode in the thermostat
- Select the pairing mode (P)
- Press the central button – the display shows 0
- Insert the receiver into the plug socket
- Press the button on the receiver 3 times – the blue LED lights up
- When the receiver is detected, the display shows OK and the digit 1 (first receiver)
- If you are using only one receiver, press the central button and exit the menu. The pairing mode is ended.

If you are going to pair multiple receivers (maximum 6), proceed as follows:

- When the first receiver is detected (digit 1 on the display),
- insert the second receiver into the plug socket.
- Press the button on the receiver 3 times – the blue LED lights up.
- When the receiver is detected, the display shows 2 (second receiver).
- Proceed similarly with the connection of subsequent receivers, then press the central button and exit the menu.

### **Caution!**

**The pairing mode is available for 10 minutes after the receiver has been connected to the mains!**

**Factory-established thermostat-receiver pairs are paired, however, pairing may be repeated if necessary.**

## 12.2. Selecting operating mode

While holding the "B" button pressed, insert the receiver into the plug socket. Depending on the mode set, the green or red LED lights up. Each time the button is pressed, the operating mode changes. When you select the mode, the receiver restores operation.

Green - normally open mode (COM – NO). It is the mainly used operation mode. While the device operation indicator is active, the output cables are shorted.

Red – normally closed mode (COM – NC). While the device operation indicator is active, the output cables are opened.

**Caution! The factory default setting is (COM-NO).**

## 13. FIRST START

When inserted into the plug socket, the receiver indicates the relay operating mode. A flash of green LED – normally open mode (COM-NO), a flash of red – normally closed mode (COM-NC). Any change in the status of the thermostat (switching the heating on/off) is made immediately by the receiver, while the confirmation that the radio signal is received from the transmitter is repeated every 15 minutes.

### 13.1. Radio signal strength

The radio signal strength is indicated together with the reception of the transmitter signal. Radio signal reception is indicated in green. LED flashing three times stands for a very strong range, twice for a strong range, and once for sufficient range.

### 13.2. No radio communication

If the communication between the thermostat and the receiver is interrupted (e.g. discharged batteries) and if this condition lasts for 60 minutes (no response from the receiver), the receiver switches to the frost protection mode. The heating device will be switched on every 3 hours for 20 minutes to prevent the rooms from being cooled down. At the time of re-establishing communication (replacement of batteries), the receiver will automatically switch the system off and resume operation.

If there is no radio communication, the green LED flashes rapidly.

### 13.3. Continuous operation of heating device (MAN)

In the event of a system failure, it is possible to manually switch on the heating. Move the switch on the RX receiver to the MAN position. Such status is indicated by a rapid flashing of the red LED. In addition, after a moment the display of the thermostat shows "On I" and  symbol.

### 13.4. Receiver signaling table.

Function	Signaling
Pairing	Blue
Reception of radio signal	Green
Lack of signal	Green – flashing
The heating device is switched on	Red
Manual operation in heating mode	Red – flashing
The air-conditioning device is switched on	Blue
Manual operation in air conditioning mode	Blue - flashing

## 14. MAINTENANCE

Do not use solvents and aggressive detergents to clean the thermostat, since they may damage the surface of the housing and the display. Clean the thermostat housing with a soft cloth.

## 15. DIMENSIONS

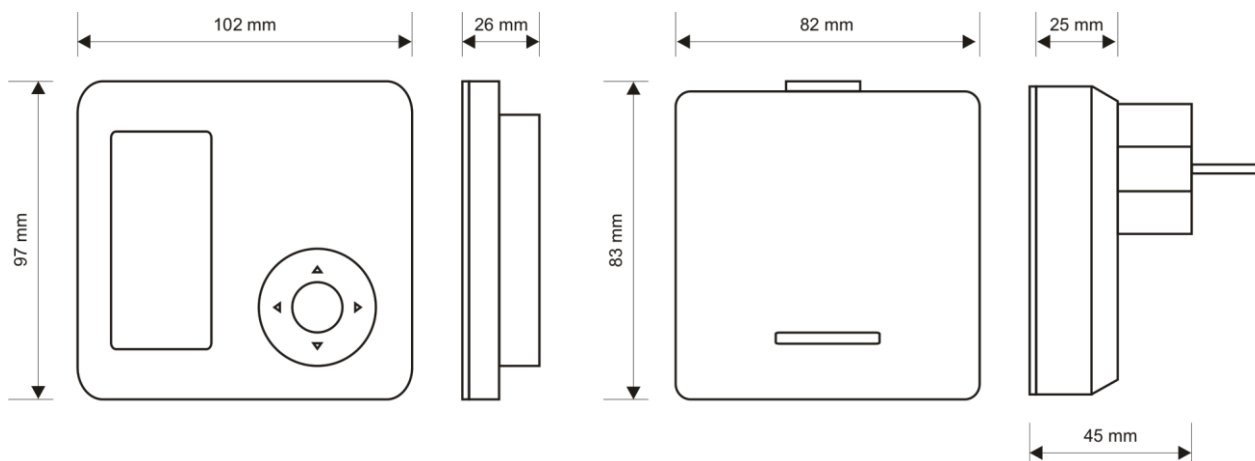

## 16. TECHNICAL DATA

Controlled device	air-conditioning / heating systems
Supply voltage	3 V (2 pieces of AAA batteries)
Thermostat output	relay, voltage-free type, SPST (normally open)
Maximum load	5 A 230 V 50 Hz
Temperature measurement range	0 °C...+99°C
Temperature control range	+5 °C...+35 °C
Temperature control accuracy	0.1°C
Temperature read-out accuracy	0.1 °C
Hysteresis range	0.2 °C... 10 °C with 0.1 °C step of the change or PWM mode
Visual signalization	backlit LCD
Operating temperature	+5 °C...+45 °C
Storage temperature	0°C...+50°C
Ingress protection rating	IP20
Color	white/gray
Installation method	thermostat – stand / receiver – 230 V 50 Hz plug socket
Thermostat weight without batteries	thermostat without batteries – 120 g / Receiver – 170 g
Frequency of operation	868 MHz
Maximum power of transmission	< 25 mW
Warranty period	2 years
Thermostat class	IV (PWM mode)
Thermostat contribution to the seasonal energy efficiency of room heating	2 % (PWM mode)

## 17. KIT CONTENTS

- Euroster 4020TXRX thermostat
- Euroster RX receiver
- 2 pieces of alkaline AAA batteries
- Installation and Operation Manual with Warranty Certificate

## 18. SIMPLIFIED DECLARATION OF CONFORMITY

P.H.P.U. AS AGNIESZKA SZYMAŃSKA-KACZYŃSKA hereby represents that the type of EUROSTER 4020TXRX equipment conforms to the following directives: 2014/35/EU (LVD), 2014/30/EU (EMC), 2014/53/EU (RED), 2011/65/EU (RoHS).

The complete text of the Declaration of EU conformity is available at the following Internet address: [www.euroster.pl](http://www.euroster.pl)

## 19. ELECTRONIC WASTE MANAGEMENT INFORMATION



This product is designed and manufactured from high-quality materials and components suitable for reuse.

The crossed-out wheelee bin symbol located on the product (Fig. 1) means that the product is subject to selective collection under the provisions of the Directive 2012/19/EU of the European Parliament and of the Council.

The product contains batteries, which are marked with a crossed-out wheelee bin symbol (Fig. 1). The batteries are subject to the selective collection under the provisions of the Directive 2006/66/EC of the European Parliament and of the Council.

Such marking informs that the electrical and electronic equipment, as well as batteries and accumulators, may not be disposed of together with other household waste after their service life has ended. The user is obliged to take the used devices and batteries or accumulators to a point of collection of waste electrical and electronic equipment and batteries and accumulators. The entities collecting such equipment, including the local collection points, shops, and municipal entities, set up an appropriate system enabling the handover of such equipment and batteries and accumulators. The proper disposal of waste equipment, batteries, and accumulators contributes to the prevention of consequences hazardous to the health of persons and nature, resulting from the possible presence of hazardous components in the equipment and batteries and inaccurate storage and processing of such equipment, batteries, and accumulators.

Households play an important role in contributing to reuse and recovery, including recycling, of waste equipment. The attitudes influencing the protection of the common good of a clean environment are shaped at this level. Households are also one of the larger users of small equipment and its rational management at this level impacts the recovery of recyclables. Inaccurate disposal of this product may be penalized in accordance with national legislation.

## WARRANTY CERTIFICATE

### EUROSTER 4020TXRX thermostat

Warranty terms:

1. The warranty is valid for 24 months from the device sale date.
2. The claimed thermostat together with this warranty certificate must be supplied to the seller.
3. Warranty claims shall be processed within 14 business days from the date the manufacturer has received the claimed device.
4. The device may be repaired exclusively by the manufacturer or by other parties explicitly authorized by the manufacturer.
5. Warranty becomes void in case of any mechanical damage, incorrect operation, and repairs made by unauthorized persons.
6. This consumer warranty does not exclude, restrict nor suspend any right of the Buyer ensuing if the product would not meet any of the sale contract terms.

.....  
Sale date

serial number  
date of manufacture

Stamp  
and signature

The business entity that issued this warranty certificate is:

P.H.P.U. AS Agnieszka Szymańska-Kaczyńska, Chumiętki 4, 63-840 Krobia, Poland