

E0101 SMART

Wired, programmable thermostat for all types of heating devices featuring remote control by a smartphone or tablet.



- Control through bespoke mobile applications for iOS and Android systems,
- Remote access using the user-friendly application,
- Integrated Wi-Fi – without the necessity to use gateways,
- Large, readable display,
- Possibility to switch the thermostat off after the heating season,
- Numerous useful functions: temporary temperature setting, constant temperature, vacation mode, display brightness control,
- The heating device hour meter (available on the application),
- Temperature read-out accuracy of 0.1 °C,
- Temperature readout correction,
- Supply voltage 230 V 50-60 Hz,
- Surface mounting.

Controlled device	Heating systems
Supply voltage	200-240 V 50/60 Hz
Receiver output	relay, voltage-free type, SPST
Maximum load	6(3) A 230 V 50 Hz
Temperature measurement range	0°C...+48.5°C
Temperature adjustment range	+5°C...+35°C
Temperature adjustment accuracy	0,2°C
Temperature readout accuracy	0.1°C
Hysteresis range	od 0,2 °C/0.4 °C/0.6 °C/0.8 °C/1 °C
Visual signalization	backlit display
Operation/Storage temperature	+5°C...+40°C / 0°C...+50°C
Wifi	2.4GHz 802.11 b/g/n
Ingress protection rating	IP20, Protection Class II
Color	white
Mounting method	wall-mounted
Weight	158 g
Warranty period	2 years
Thermostat class	I
Contribution to energy efficiency	1 %
Dimensions width/height/depth (in mm)	126/85/25
Thermostat kit contains	Euroster 0101 SMART, screw anchors, user manual with warranty certificate



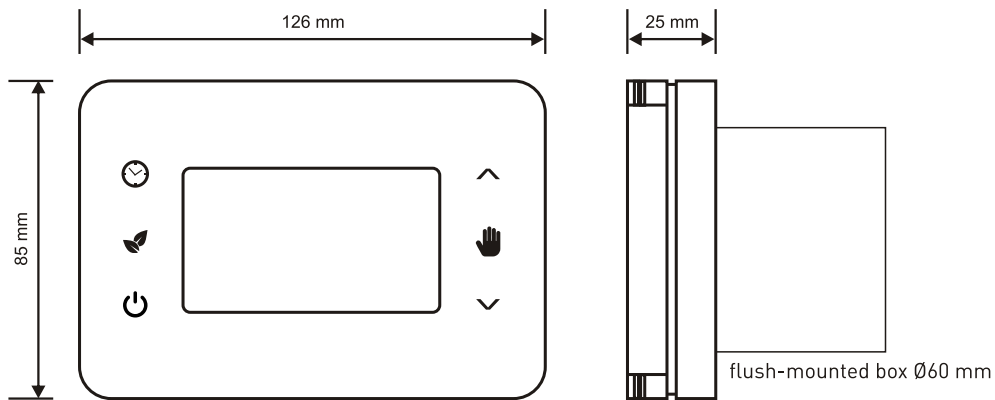

The following diagrams are simplified and do not cover all elements necessary for the correct installation.

IN A SYSTEM WITH A GAS BOILER

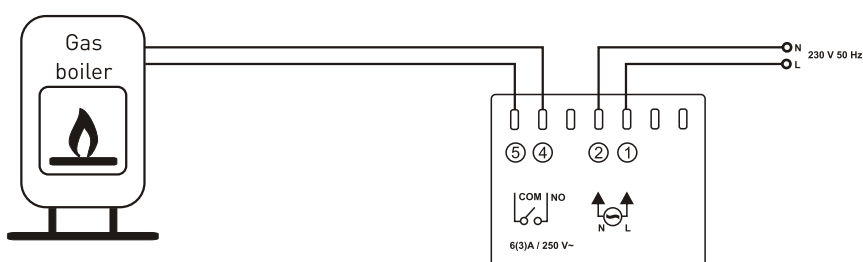

IN ARRANGEMENT WITH A 230 V 50 HZ HEATING DEVICE

